

CAD FILE:

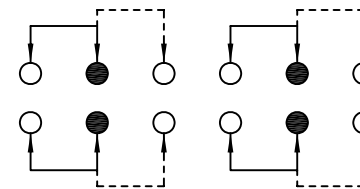

**SCHEMATIC(NON-SHORTING)**

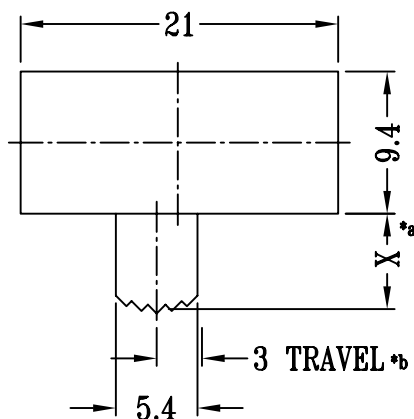
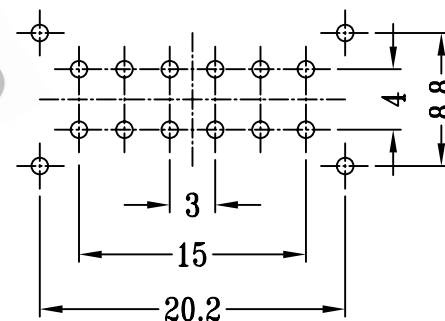
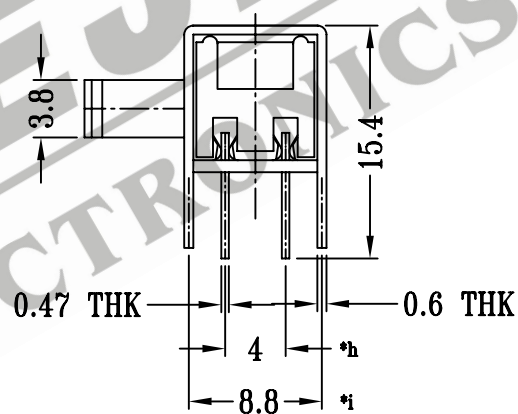
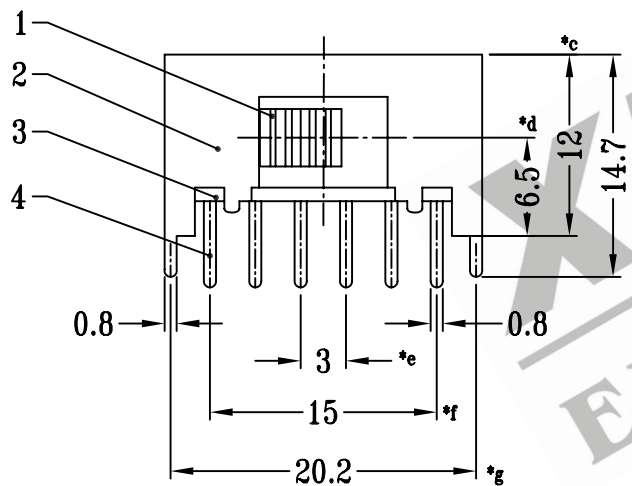

**P.C.B LAYOUT**

注：“\*”表示关键尺寸（9个）

NO.	PARTS	MATERIALS	Q'TY	FINISH	TOLERANCE UNLESS SPECIFIED	SHENZHEN XIEJIA ELECTRONICS CO.,LTD.					
8						TITLE : HORIZONTAL L SLIDE SWITCH		UNIT : mm	DRWG NO.: XJ-DR-SK42F01-00		
7	STEEL BALL	STEEL	1	NATURAL	WITHIN: 1.5 ±0.1mm	MODEL: SK-42F01		SCALE: 2:1	DWN.	ZHOUYU	2005-9-5
6	SPRING	STEEL WIRE	1	TEMPER	OVER: 1.5 ±0.2mm				CHK'D	FANGYING	2005-9-5
5	CONTACT CLIP	PBS STRIP	4	Ag PLATED		ISSUE	DATE	DESCRIPTIONS OF REVISION		APPD.	
4	TERMINAL	BRASS STRIP	12	Ag PLATED OVER Ni PLATED							
3	BASE	PHENOLIC RESIN	1	NATURAL							
2	FRAME	STEEL STRIP	1	Ni PLATED							
1	KNOB	POM	1	BLACK							
					ALL MATERIALS MUST BE COMPLIANT TO ROHS				APPD.	KANGXINAN	2005-9-5